



# STM Series



## TRUCK MOUNTED FORKLIFT

**5,500 - 7,000 lb Capacity**

**Models Include:**

- Three Wheel Drive
- 4WAY Multi-directional
- Pantograph Reach

Powerful - Dependable

## STM SERIES

STM55 / STM55P / STM55-4W (4WAY) / STM70

Lift capacities: 5,500 • 7,000 lbs @ 24" load center

### ● Engine

- KOHLER KDI 1903TCR Tier 4, 56 HP, direct injection diesel engine.
- Exceptional low end torque.
- No exhaust aftertreatment, Diesel Particulate Filter (DPF) or Diesel Exhaust Fluid (DEF) required.
- Dual element air filter.
- Water separator.
- Cold weather preheat and starting aid.



### ● Instrumentation

- Multi-function LCD digital display includes fuel level, engine coolant temperature, system voltage, rpm and hour meter reading.
- Easy to understand text formatted messages for operational guidance.
- On-board diagnostics provide real time system messages for troubleshooting.



### ● Drive System

- EZ Trac hands-free traction control.
- Full-time anti-stall.
- Integral inching/brake pedal for precise control.
- Proven, quality, drive train components
- Multi-directional, intuitive steering available to carry long loads in tight spaces.



**SELICK**

STM TRUCK MOUNTED FORKLIFT

# Agile - Versatile

## STM SERIES

Designed to meet the demands of the building product industries

Call Sellick today to discuss your needs or visit [www.sellickequipment.com](http://www.sellickequipment.com)

### ● Operator Compartment

- EZ Drive automotive inspired controls for safe and efficient operation.
- Roomy operator platform with operator presence control.
- Platform meets or exceeds ANSI B56.14 ROPS/FOPS safety standards.
- Operator's manual storage compartment.
- Heat producing elements of the machine are engineered away from the operator.
- Optional full cab with heat, wipers and sliding windows.



### ● Mounting

- Universal, easy to install mounting kit fits most trucks/trailers.
- Compatible with existing mounts (factory approval required).

### ● Tires

- 31" all-terrain tires for high flotation.
- Optional sizes/tread patterns for various applications.



### ● Mast Assemblies

- Sellick built mast features corrosion resistant chains, sealed rollers and mast sideshift for reduced maintenance costs.
- Lift heights to 8, 10 and 12 feet.
- Optional hydraulic fork positioning carriage.



STM TRUCK MOUNTED FORKLIFT

# STM TRUCK MOUNTED FORKLIFT

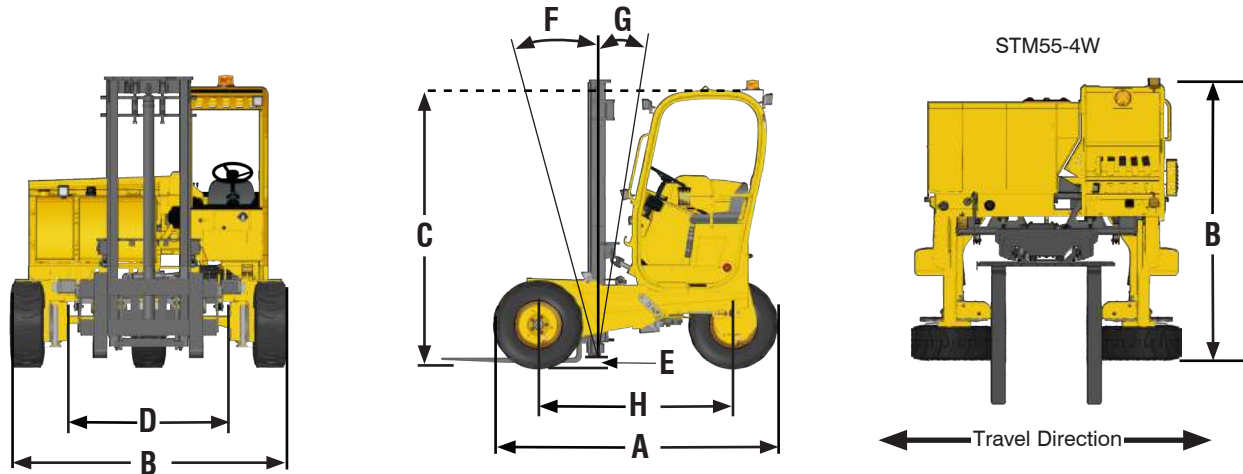

Model	Ref	STM55	STM55P	STM55-4W	STM70
Lift capacities @ 24" load center		5,500 lbs/2,500 kg			7,000 lbs/3,175 kg
Base operating weight (without forks)*		6,560 lbs/2,976 kg	7,590 lbs/3,443 kg	8,285 lbs/3,758 kg	6,690 lbs/3,035 kg
Overall length (without forks)	A	102"/2,591 mm	105.5"/2,680 mm	99"/2,515 mm	105.5"/2,680 mm
Overhang		63"/1,600 mm	73"/1,854 mm	62"/1,575 mm	67"/1,702 mm
Overall width	B	100"/2,540 mm		101"/2,565 mm	100"/2,540 mm
Height to top of OHG	C	96"/2,438 mm		98"/2,489 mm	96"/2,438 mm
Frame opening	D	60"/1,524 mm		58.5"/1,486 mm	60"/1,524 mm
Outside turning radius (standard)		120"/3,048 mm			123"/3,124 mm
Mast sideshift		6"/152 mm			
Mast underclearance	E	12"/305 mm		8"/203 mm	12"/305 mm
Mast tilt - forward	F	12°			
Mast tilt - rearward	G	8°			
Gradeability		25%			
Wheelbase	H	66"/1,676 mm	74"/1,880 mm	67"/1,702 mm	74"/1,880 mm
Tire size		31.5 - 15.5 - 15		31.5 - 13 - 16.5	31.5 - 15.5 - 15
Engine build/model		Kohler KDI 1903TCR Tier 4 compliant			
Engine type		Diesel, turbocharged, electronic			
Cylinders		3			
Engine output		56 hp			
Transmission type		Hydrostatic			

*Because of our constant dedication to product improvement, all specifications are subject to change without notice.  
-All Sellick truck-mounted forklifts meet or exceed ANSI/ITSDF B56.14 - 2015 Standards for Vehicle Mounted Forklift Trucks.-*



**Sellick Equipment Limited**

P.O. Box 1000/358 Erie Street North  
Harrow, Ontario, Canada N0R 1G0  
519-738-2255 • sellick@mnsi.net  
Visit us at [www.sellickequipment.com](http://www.sellickequipment.com)



Sold & serviced by: